



3M

2 Pole Models
2900 RPM

**Stainless Steel
End Suction Pumps**

(DIN 24255)



**Monobloc Design
304 Stainless Steel**



-SPECIFICATIONS	Page
<u>Features & Applications</u>	<u>100</u>
<u>Typical Cross Sectional View</u>	<u>101</u>
<u>Pump & Motor Specifications</u>	<u>102</u>
<u>Selection Charts</u>	<u>103</u>
<u>Curve Specifications</u>	<u>104</u>
-PERFORMANCE CURVES	
<u>Performance Curve – 3M 32-125/1.1</u>	<u>200</u>
<u>Performance Curve – 3M 32-160/1.5/2.2</u>	<u>201</u>
<u>Performance Curve – 3M 32-200/3/4/5.5</u>	<u>202</u>
<u>Performance Curve – 3M 40-125/1.5/2.2</u>	<u>203</u>
<u>Performance Curve – 3M 40-160/3/4</u>	<u>204</u>
<u>Performance Curve – 3M 40-200/5.5/7.5/11</u>	<u>205</u>
<u>Performance Curve – 3M 50-125/2.2/3/4</u>	<u>206</u>
<u>Performance Curve – 3M 50-160/5.5/7.5</u>	<u>207</u>
<u>Performance Curve – 3M 50-200/9.2/11/15</u>	<u>208</u>
-CONSTRUCTIONS	
<u>Constructions – Sectional View</u>	<u>300</u>
<u>Constructions – Mechanical Seal</u>	<u>301</u>
<u>Constructions – Electrical Connections</u>	<u>302</u>
<u>Constructions – Companion Flange</u>	<u>303</u>
-DIMENSIONS	
<u>Dimensions</u>	<u>400</u>
<u>Packing and Weight</u>	<u>401</u>
-TECHNICAL DATA	
<u>Technical Data – Motor Data</u>	<u>500</u>

E.&O.E. All care has been taken to ensure the accuracy of the information and is correct to the best of our knowledge and is given without guarantee. Specifications subject to change without notice.



These stainless steel pumps feature a unique one piece volute casing that is produced using an advanced computer controlled plasma stamping system that ensures total quality control during manufacture. With the smooth surfaces of stamped stainless steel, this results in consistent high standard products, of superior quality and high efficiency.

Features

- Stainless steel liquid end components
 - High quality; corrosion resistance.
 - Manufactured in Stamped 304 Stainless Steel.
- Economical extended motor shaft design.
- High quality mechanical shaft seals and o-rings
 - Fitted standard with Carbon/Ceramic/NBR mechanical seal.
- Close coupled design
 - Saves space; simplifies maintenance and installation.
- Back pullout construction
 - Assembly and overhaul of the impeller and seal without disturbing suction and discharge connections.
- High operating efficiency
 - Lowers operating costs.
- Top centerline discharge and foot support under casing
 - Ensures self-venting and reduces misalignment from pipe loads.

Applications

- Plant services
- Water supply systems
- Washing plants
- Cooling water
- Air conditioning
- Sprinkler/flow irrigation
- OEM equipment application
- Pressure boosting
- Liquid transfer
- Heat exchanger
- Spray systems
- Heating
- Water reclamation and treatment



SPECIFICATIONS - TYPICAL EXPLODED VIEW

2 Pole 50Hz

V14

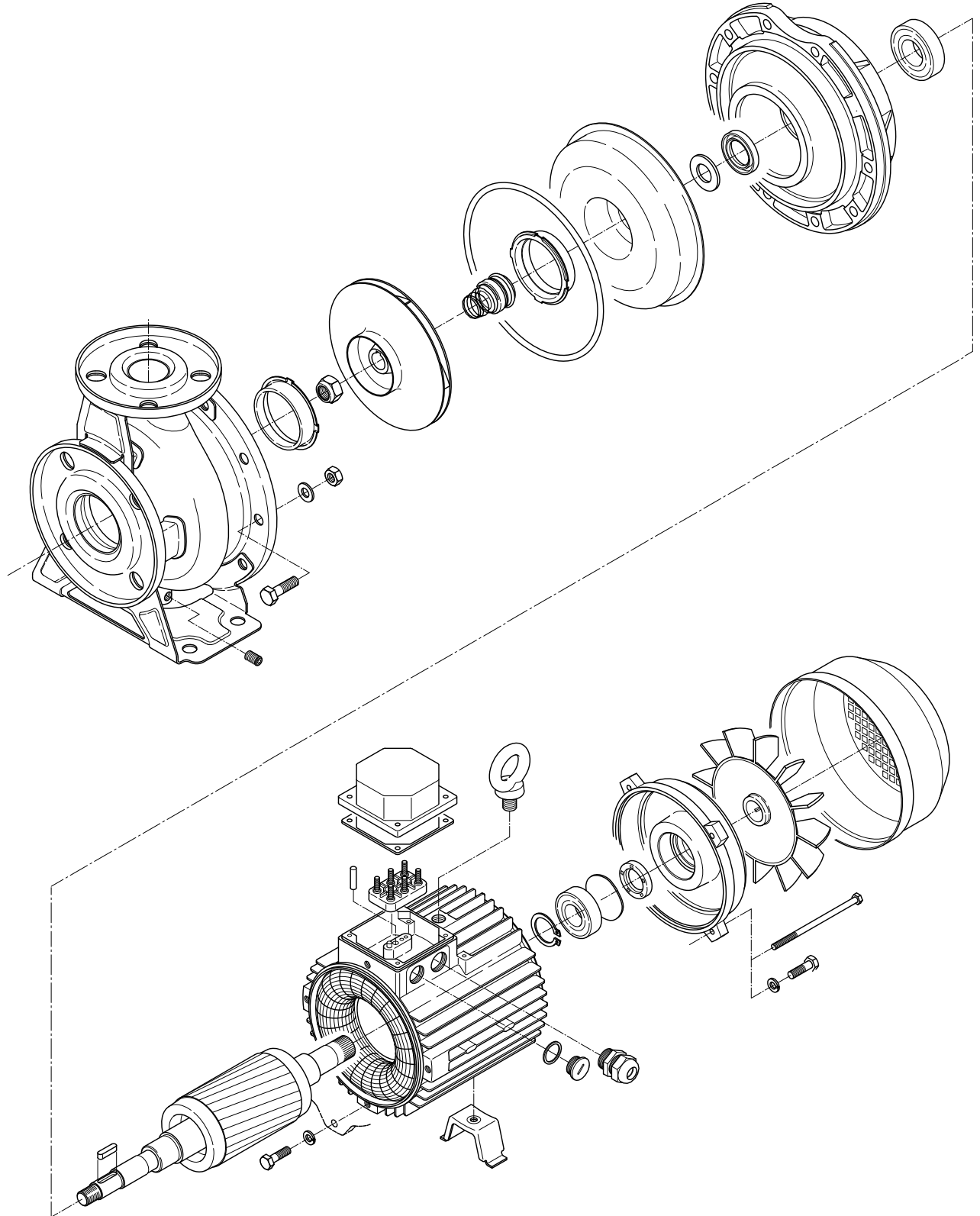

SPECIFICATIONS

2 Pole 50Hz

V14

PUMP				
Version		3M		
Liquid Handled	Type of liquid	Clean water		
	Temperature [°C]	min. -10 max. +90 max. +110 (H-HS-version)		
Maximum working pressure [MPa]		1		
Construction	Impeller	Closed centrifugal type for 32, 40, 50 version Reinforced laser welding for 40-200/11, 50-		
	Shaft seal type	Mechanical seal		
	Bearing	Sealed ball bearing		
Pipe Connection	Suction	32-125/160/200	Flange DN50 according DIN 2532 Standard	
		40-125/160/200	Flange DN65 according DIN 2532 Standard	
		50-125/160/200		
	Discharge	32-125/160/200	Flange DN32 according DIN 2532 Standard	
		40-125/160/200	Flange DN40 according DIN 2532 Standard	
50-125/160/200	Flange DN50 according DIN 2532 Standard			
Material	Casing	304 Stainless Steel		
	Impeller	304 Stainless Steel		
	Casing cover	316L Stainless Steel		
	Mechanical Seal	Ceramic/Carbon/NBR		
	O-ring	NBR (FPM for H, HS Version)		
	Shaft	32, 40, 50 D=19	EN 1.4301 (AISI 304)	
		50-200/15 D=22		
Bracket	Cast Iron - Aluminum			
Applicable Standard of test		ISO 9906 – Annex A		
MOTOR – Three Phase				
Efficiency level (Reg. 640/2009)		IE2		
No. of Poles		2		
Rotation Speed [min ⁻¹]		~2900		
Insulation Class		F		
Protection Degree (CEI EN 60034-5)		IP 55		
Frequency		50Hz		
Voltage [V]		230/400±10%(up to 4.0 kW) 400/690±10%(5.5 kW and above)		
Over load Protection		Provided by user		
Casing Material		Aluminum		
Motor support		Cast Iron – Aluminum		
Dimensions of cable entry		PG13.5 – PG16 – PG21		

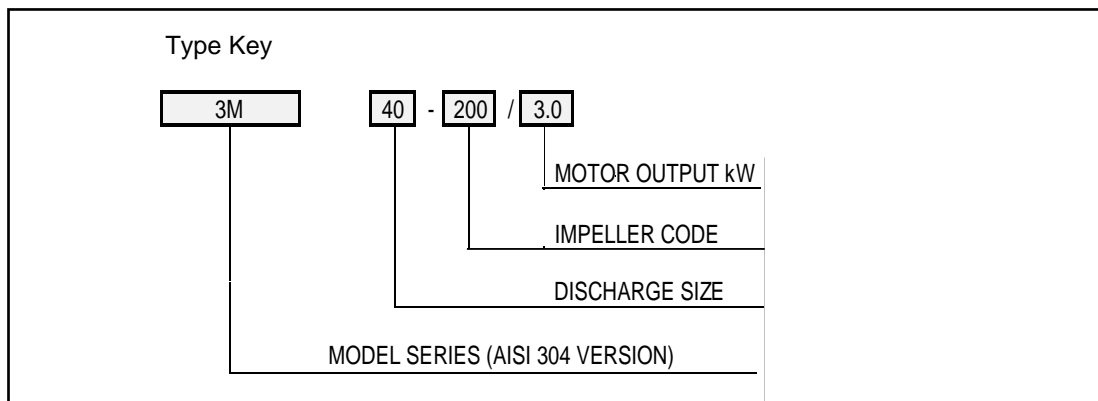

SELECTION CHART

2 Pole 50 Hz

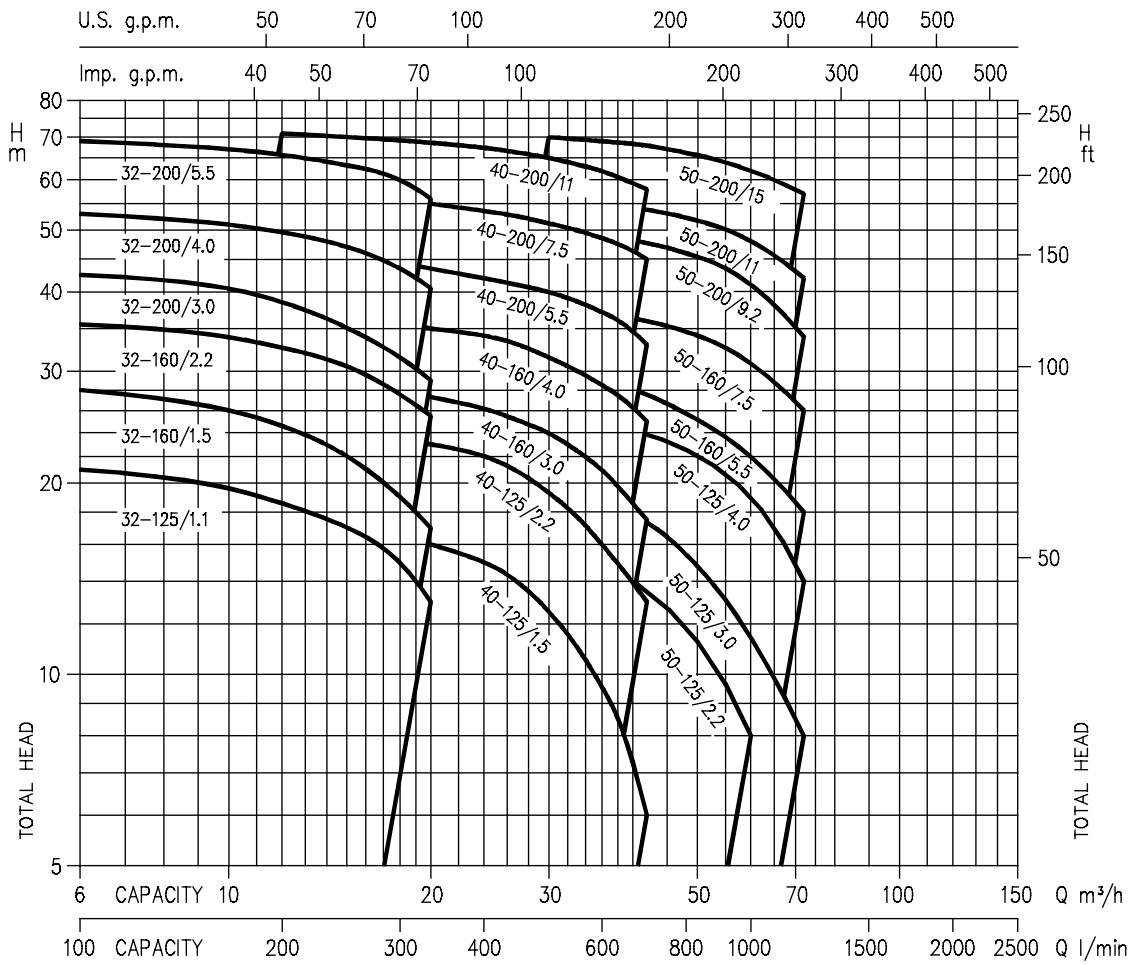

Pump type	Power		Capacity (Q)																
	[kW]	[HP]	l/min m³/h	0	100	150	200	300	333	360	400	450	500	600	700	800	1000	1200	
32-125/1.1	1.1	1.5	22.5	21	19.9	18.4	14.1	12	-	-	-	-	-	-	-	-	-	-	-
32-160/1.5	1.5	2	29.5	28	26.5	24.5	19.2	17	-	-	-	-	-	-	-	-	-	-	-
32-160/2.2	2.2	3	37	35.5	34	32	27	25	-	-	-	-	-	-	-	-	-	-	-
32-200/3.0	3	4	44	42	40	37.5	31	28	-	-	-	-	-	-	-	-	-	-	-
32-200/4.0	4	5.5	55	53.5	52	49.5	43.5	40.5	38	-	-	-	-	-	-	-	-	-	-
32-200/5.5	5.5	7.5	70.5	69	67.5	65	58.5	-	-	-	-	-	-	-	-	-	-	-	-
40-125/1.5	1.5	2	20	-	-	19	17.6	17	16.5	15.7	14.5	13.2	10.3	7	-	-	-	-	-
40-125/2.2	2.2	3	26.5	-	-	25.5	24	23.5	23	22	21	19.5	16.4	13	-	-	-	-	-
40-160/3.0	3	4	31	-	-	29.5	27.5	27	26.5	25.5	24	22.5	20	17	-	-	-	-	-
40-160/4.0	4	5.5	40	-	-	38.5	37	36	35.5	34.5	33	32	29	25.5	-	-	-	-	-
40-200/5.5	5.5	7.5	47	-	-	45.5	44	43	42.5	41	39.5	38	35	31	-	-	-	-	-
40-200/7.5	7.5	10	58	-	-	57	55.5	55	54.5	53.5	52.5	51	47.5	44	-	-	-	-	-
40-200/11	11	15	72	-	-	71	70	70	69.5	68.5	67.5	66	63	59	-	-	-	-	-
50-125/2.2	2.2	3	19	-	-	-	-	-	-	17.5	17	16.3	14.9	13.4	11.7	8	-	-	-
50-125/3.0	3	4	22	-	-	-	-	-	-	20.5	20	19.6	18.4	17	15.4	11.8	8	-	-
50-125/4.0	4	5.5	26.5	-	-	-	-	-	-	26	25.5	25	24	22.5	21.5	17.9	14	-	-
50-160/5.5	5.5	7.5	33	-	-	-	-	-	-	31	30.5	30	28.5	27	25.5	22	18	-	-
50-160/7.5	7.5	10	40	-	-	-	-	-	-	38.5	38	37.5	36	35	33.5	30	26	-	-
50-200/9.2	9.2	12.5	53	-	-	-	-	-	-	-	-	50	49	47.5	45.5	40.5	34	-	-
50-200/11	11	15	59	-	-	-	-	-	-	-	-	56	55	54	52	48	42	-	-
50-200/15	15	20	72	-	-	-	-	-	-	-	-	70	69	68	66	62	57	-	-

The minimum efficiency index (MEI) is a measure of the quality of a pump size in respect to its mean efficiency. The minimum efficiency index is based on the hydraulic efficiency and on the head at the best efficiency point.

The efficiency of a pump with trimmed impeller is usually lower than that of a pump with the full impeller diameter. The trimming of the impeller will adapt the pump to a fixed duty point, leading to a reduced energy consumption. The minimum efficiency index (MEI) is based on the full impeller diameter.

The operation of these water pumps with variable duty points may be more efficient and economical when controlled, for example, by the use of a variable speed drive that matches the pump duty to the system.

MEI = 0.4 for ESCC 2900 rpm

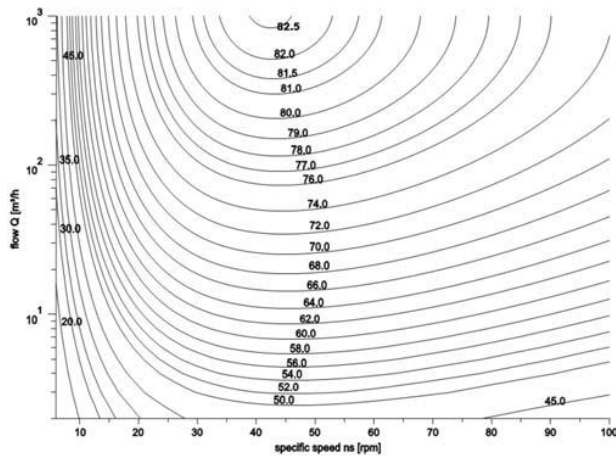

MEI = 0.7 for ESCC 2900rpm

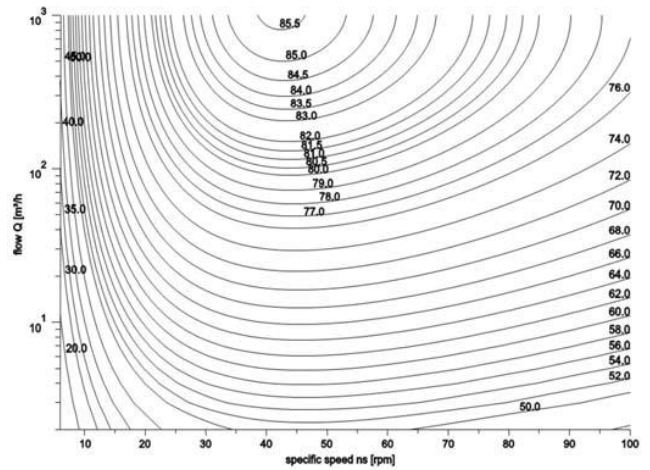

32-125/1.1 (1.1kW) MEI > 0.40 – impeller diameter = 133 mm

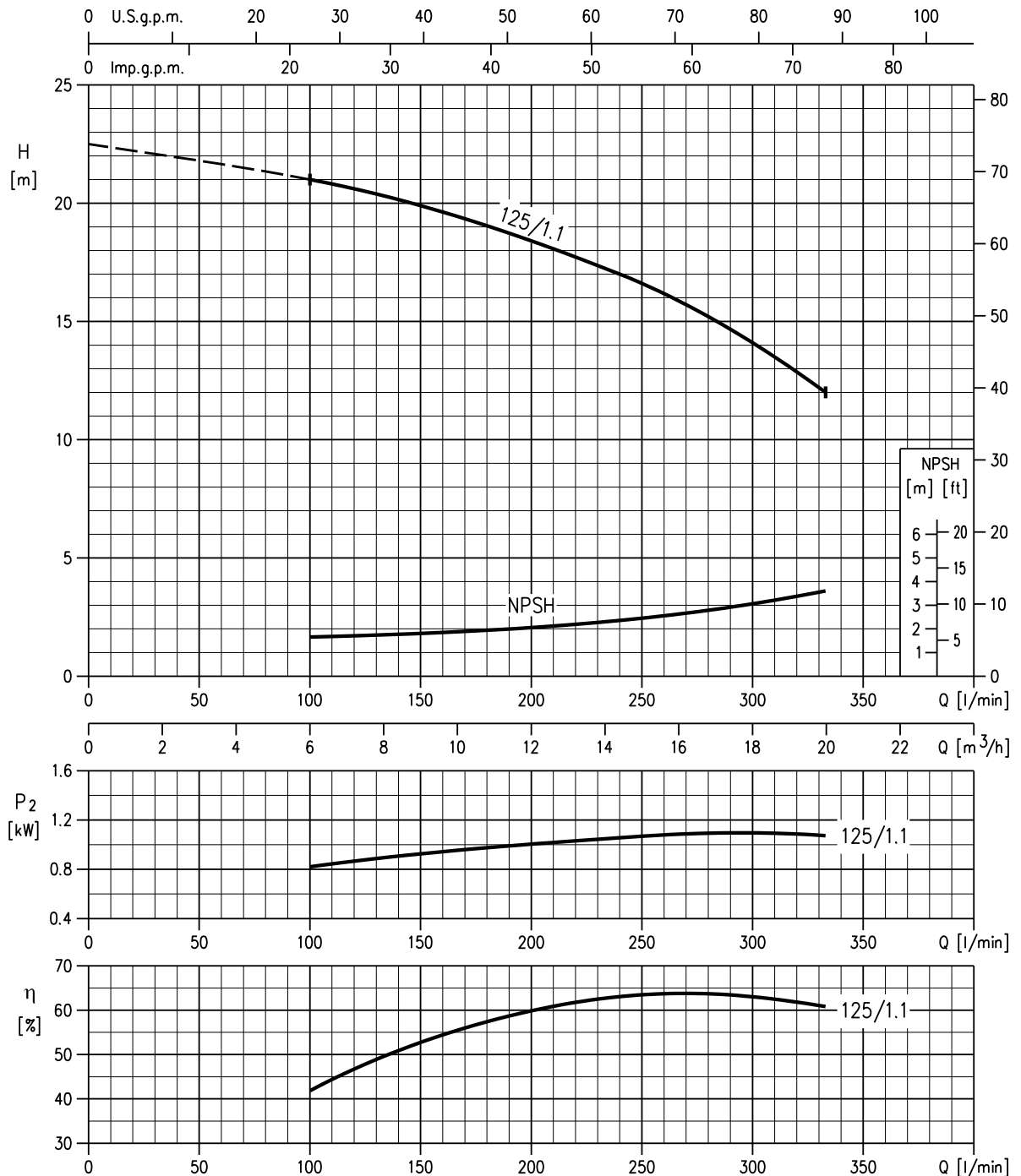

Rotation speed ≈ 2900 min⁻¹
 Test standard: ISO 9906 – Annex A

32-160/1.5 (1.5kW) MEI > 0.70 – impeller diameter = 151 mm
 32-160/2.2 (2.2kW) MEI > 0.70 – impeller diameter = 166 mm

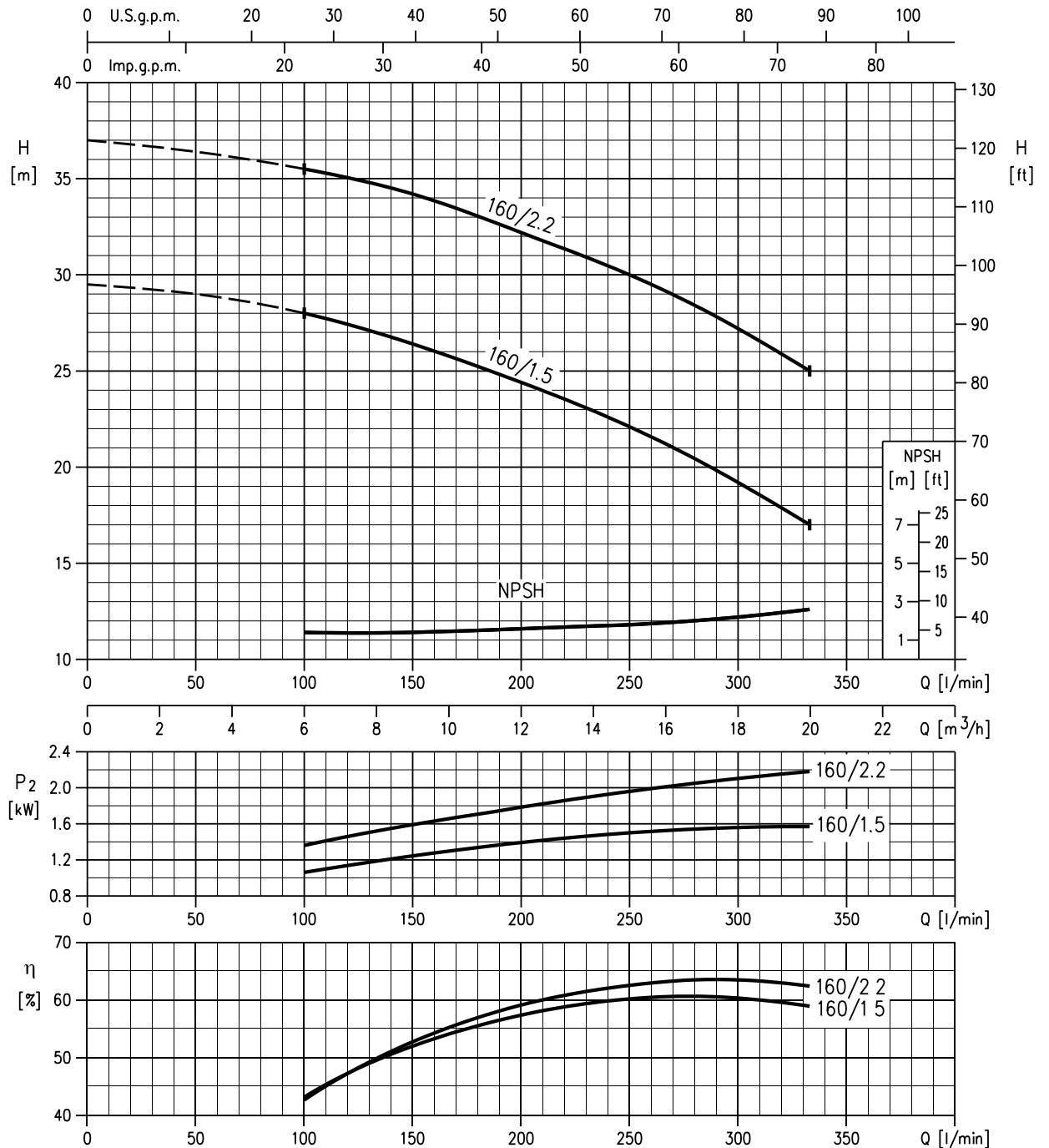

Rotation speed ≈ 2900 min⁻¹
 Test standard: ISO 9906 – Annex A

PERFORMANCE CURVE

2 Pole 50Hz

V14

32-200/3 (3.0kW) MEI > 0.70 – impeller diameter = 186 mm
32-200/4 (4.0kW) MEI > 0.70 – impeller diameter = 200 mm
32-200/5.5 (5.5kW) MEI > 0.70 – impeller diameter = 224 mm

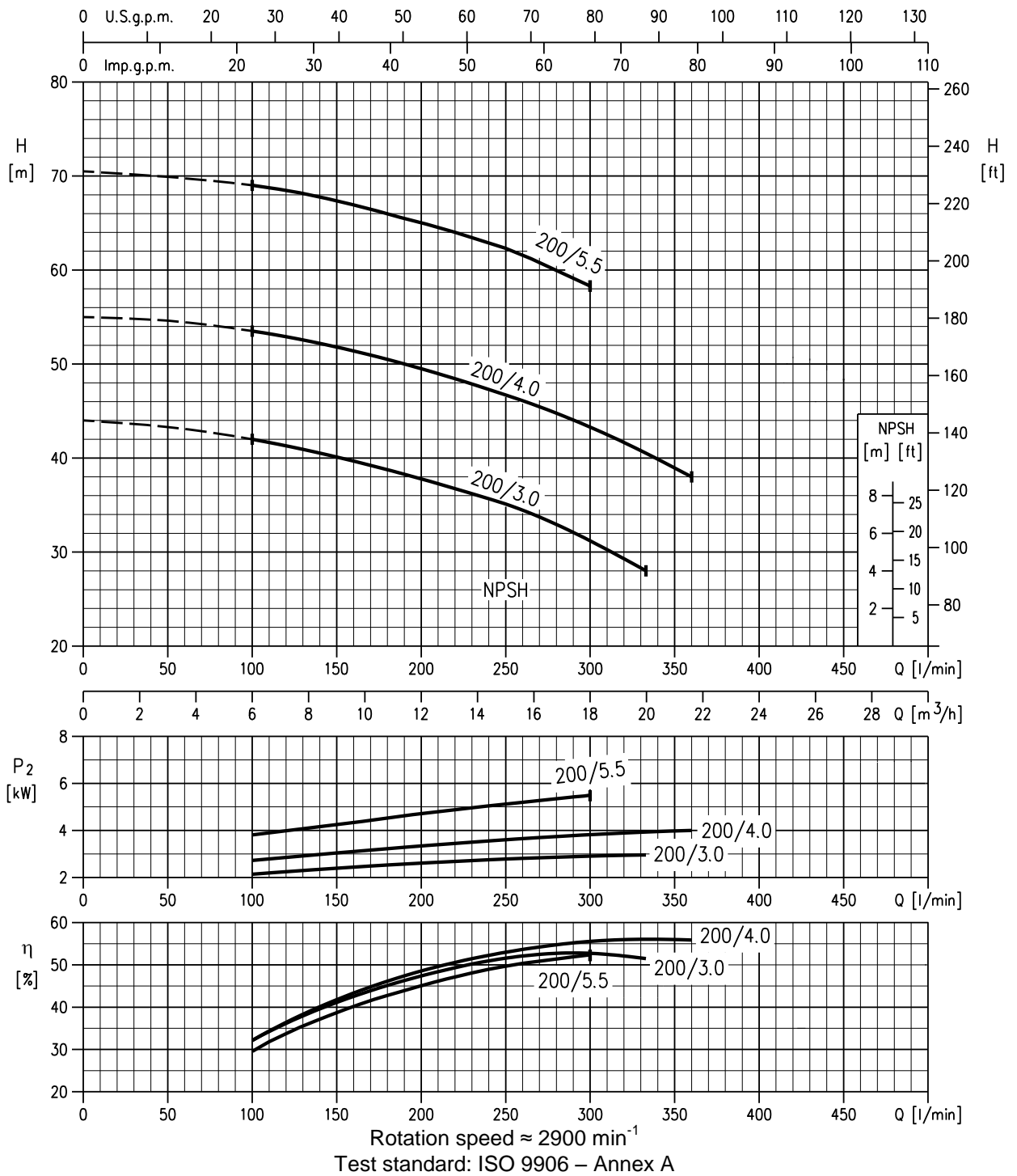

40-125/1.5 (1.5kW) MEI > 0.70 – impeller diameter = 125 mm
 40-125/2.2 (2.2kW) MEI > 0.70 – impeller diameter = 140 mm

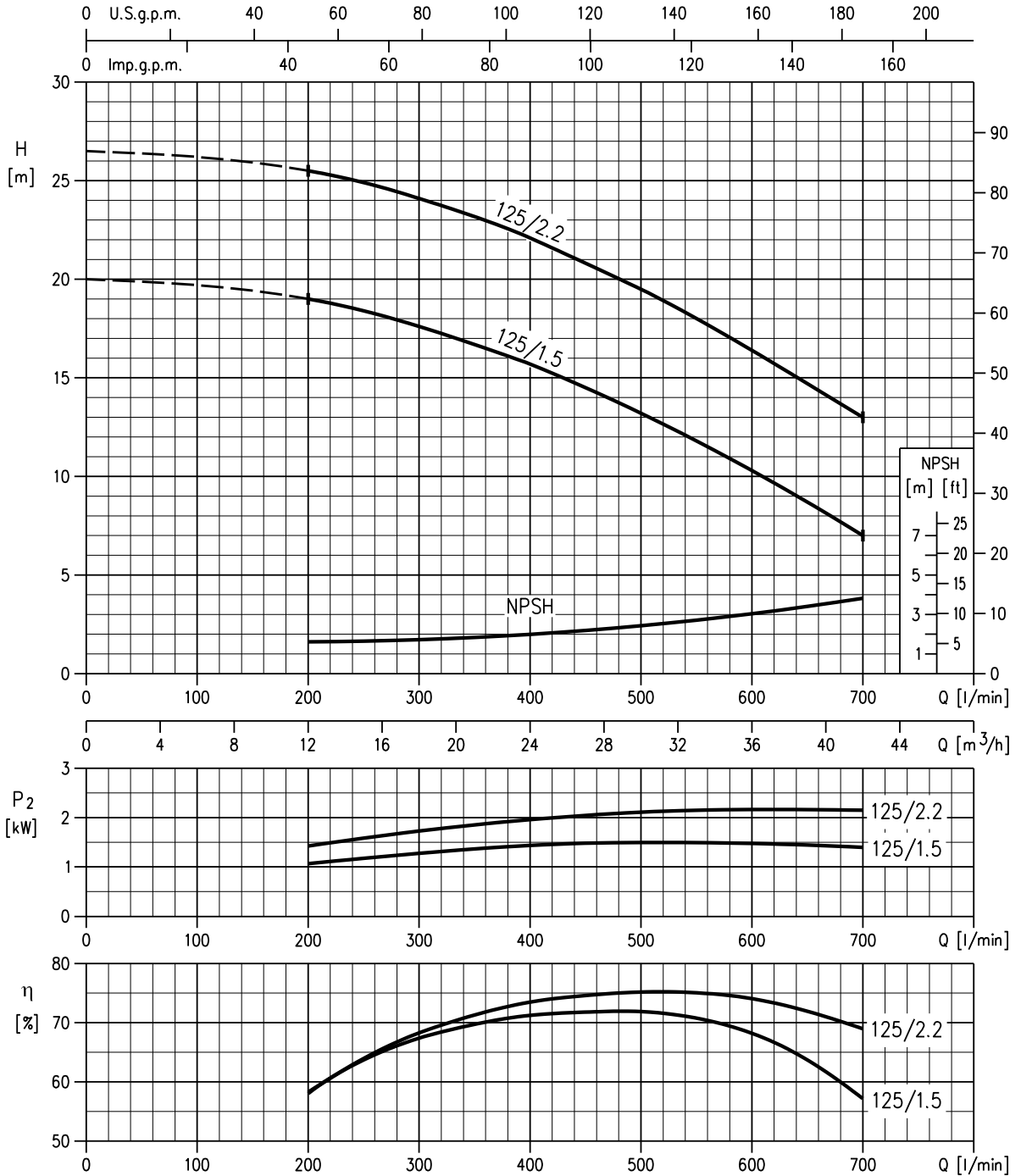

Rotation speed ≈ 2900 min⁻¹
 Test standard: ISO 9906 – Annex A

40-160/3 (3.0kW) MEI > 0.70 – impeller diameter = 151 mm
 40-160/4 (4.0kW) MEI > 0.70 – impeller diameter = 166 mm

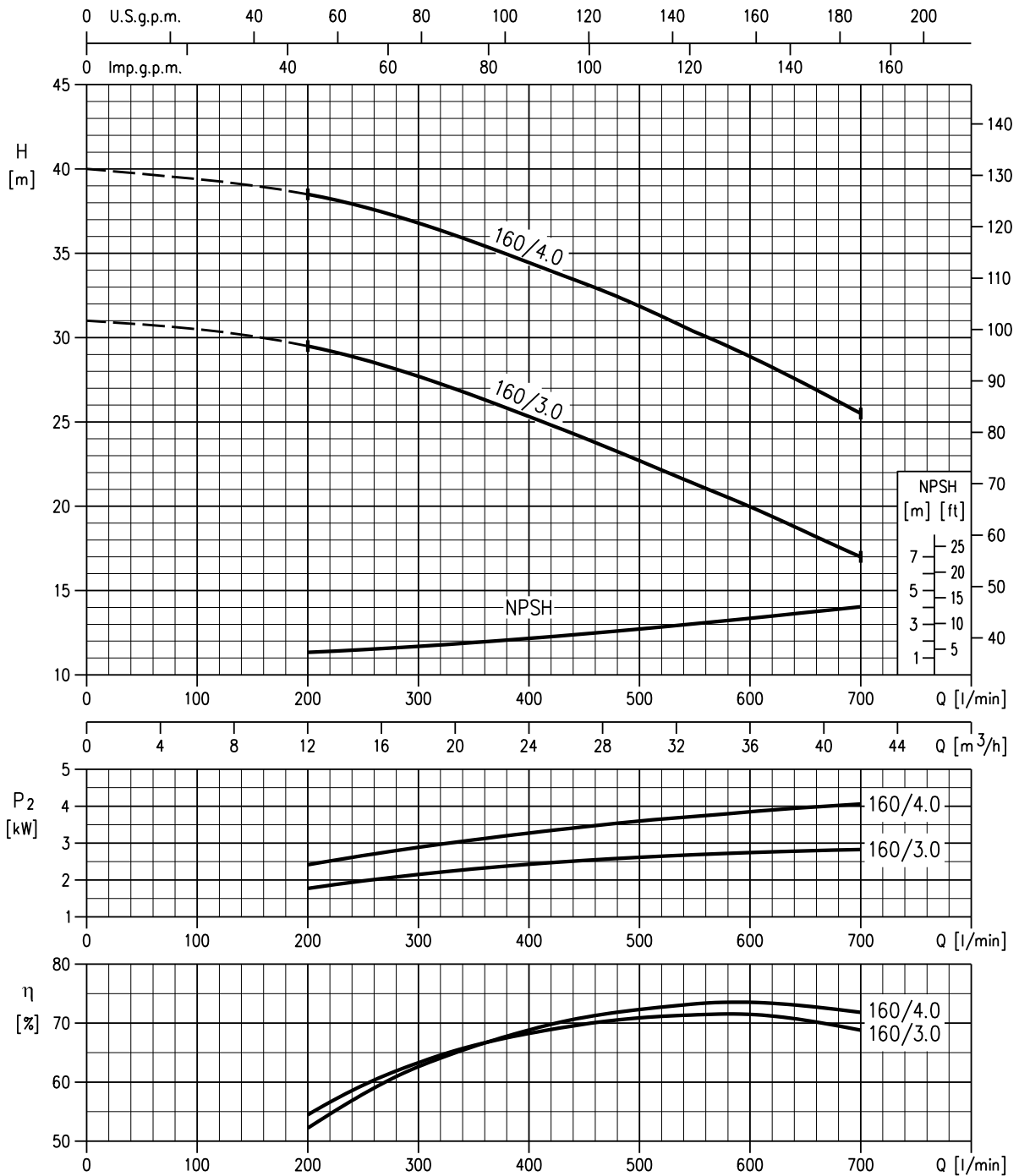

Rotation speed ≈ 2900 min⁻¹
 Test standard: ISO 9906 – Annex A

PERFORMANCE CURVE

2 Pole 50Hz

V14

40-200/5.5 (5.5kW) MEI > 0.70 – impeller diameter = 183 mm
 40-200/7.5 (7.5kW) MEI > 0.70 – impeller diameter = 200 mm
 40-200/11 (11kW) MEI > 0.70 – impeller diameter = 224 mm

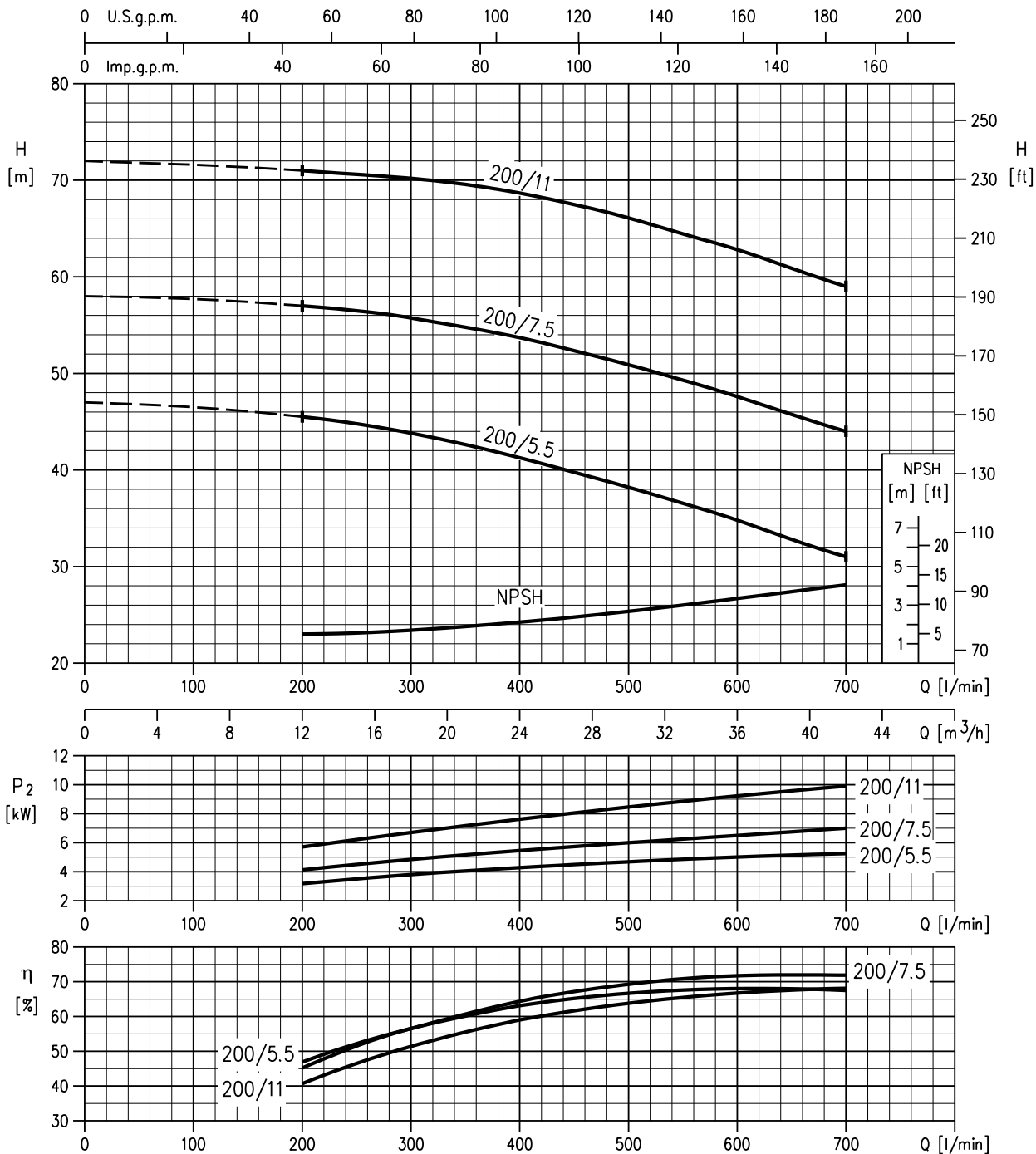

Rotation speed $\approx 2900 \text{ min}^{-1}$
 Test standard: ISO 9906 – Annex A

PERFORMANCE CURVE

2 Pole 50Hz

V14

50-125/2.2 (2.2kW) MEI > 0.50 – impeller diameter = 126 mm

50-125/3 (3.0kW) MEI > 0.50 – impeller diameter = 131 mm

50-125/4 (4.0kW) MEI > 0.50 – impeller diameter = 140 mm

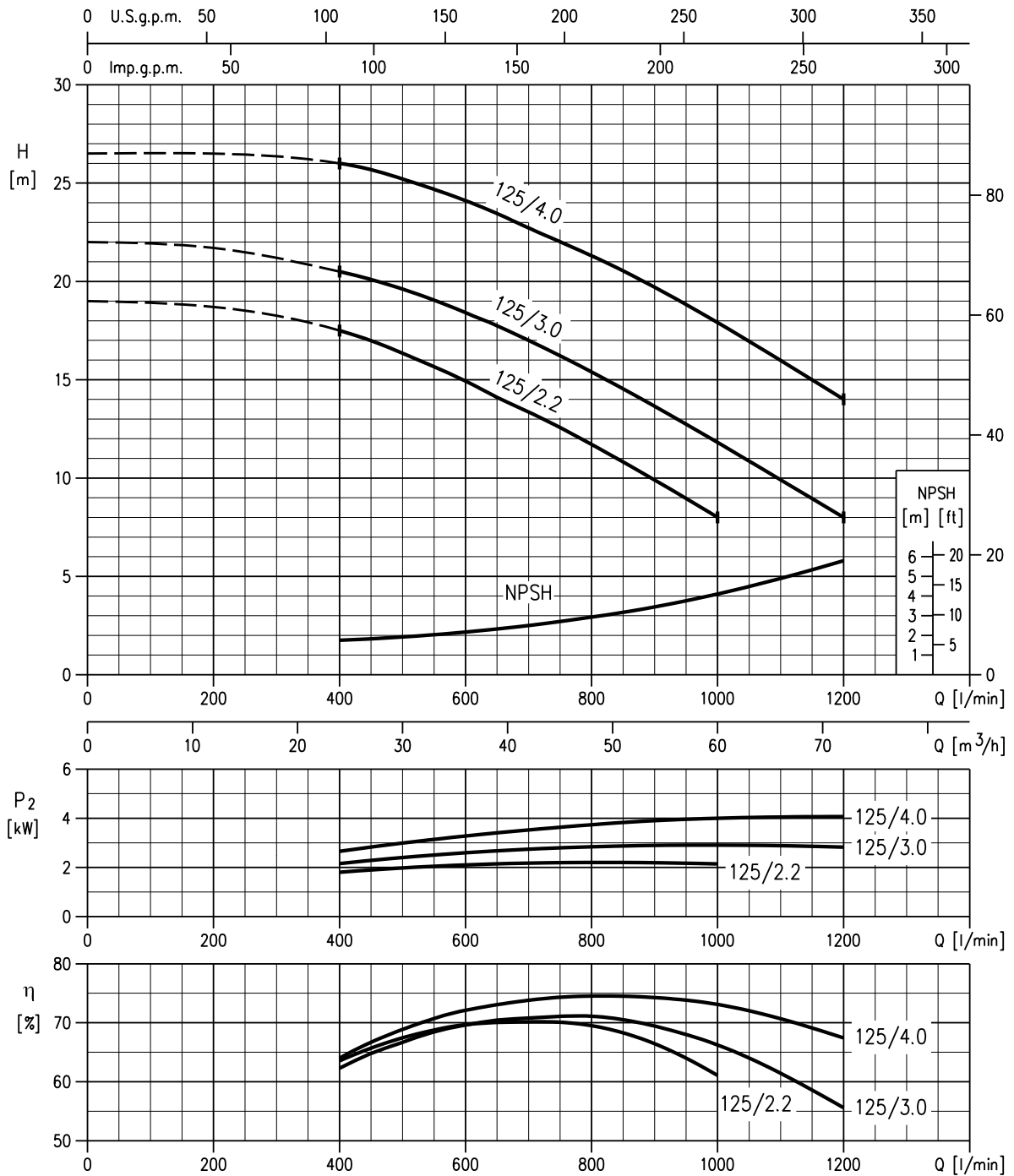

Rotation speed $\approx 2900 \text{ min}^{-1}$
 Test standard: ISO 9906 – Annex A

PERFORMANCE CURVE

2 Pole 50Hz

V14

50-160/5.5 (5.5kW) MEI > 0.40 – impeller diameter = 154 mm

50-160/7.5 (7.5kW) MEI > 0.40 – impeller diameter = 166 mm

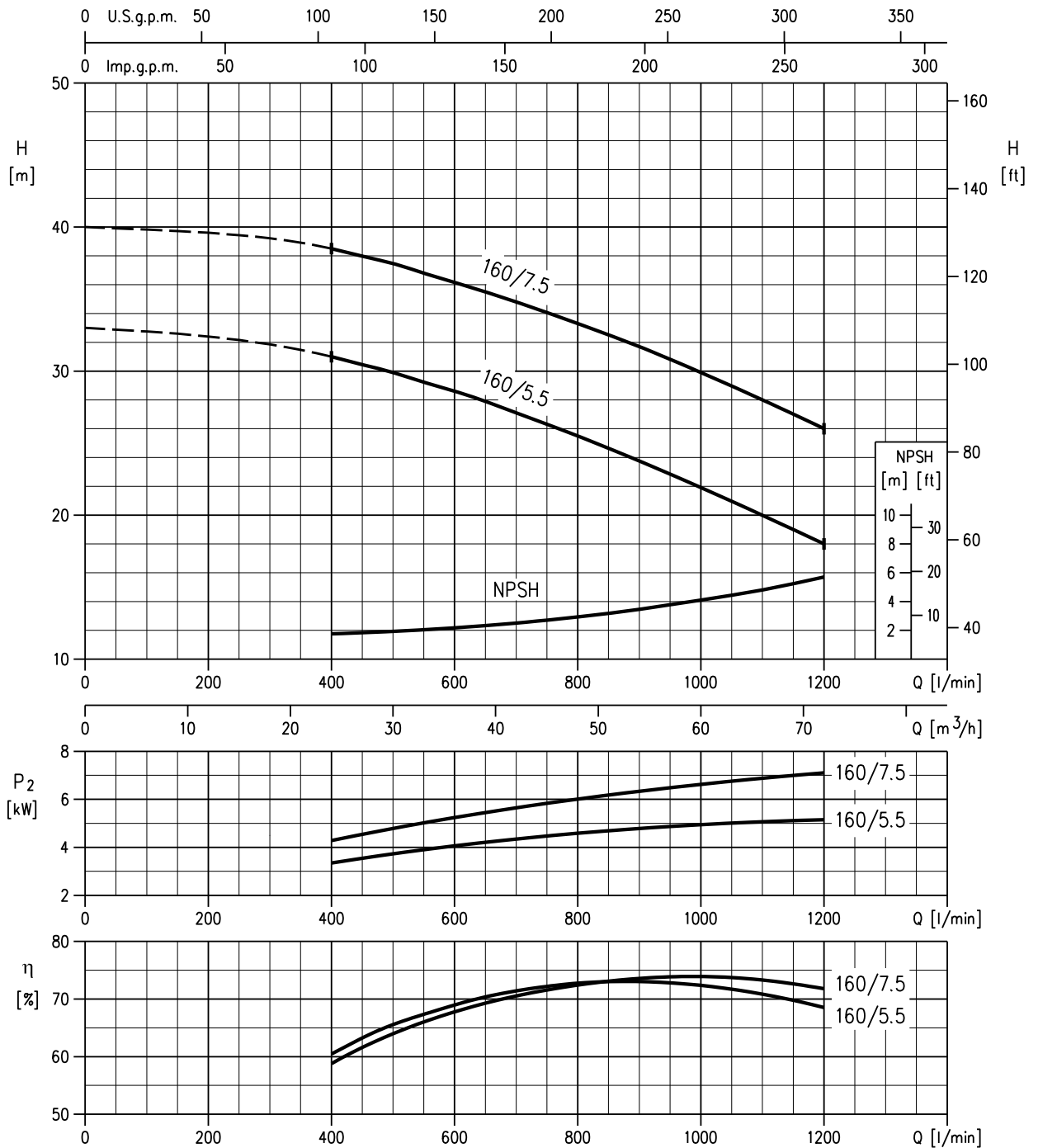

Rotation speed ≈ 2900 min⁻¹
 Test standard: ISO 9906 – Annex A

PERFORMANCE CURVE

2 Pole 50Hz

V14

50-200/9.2 (9.2kW) MEI > 0.70 – impeller diameter = 191 mm
50-200/11 (11kW) MEI > 0.70 – impeller diameter = 200 mm
50-200/15 (15kW) MEI > 0.40 – impeller diameter = 224 mm

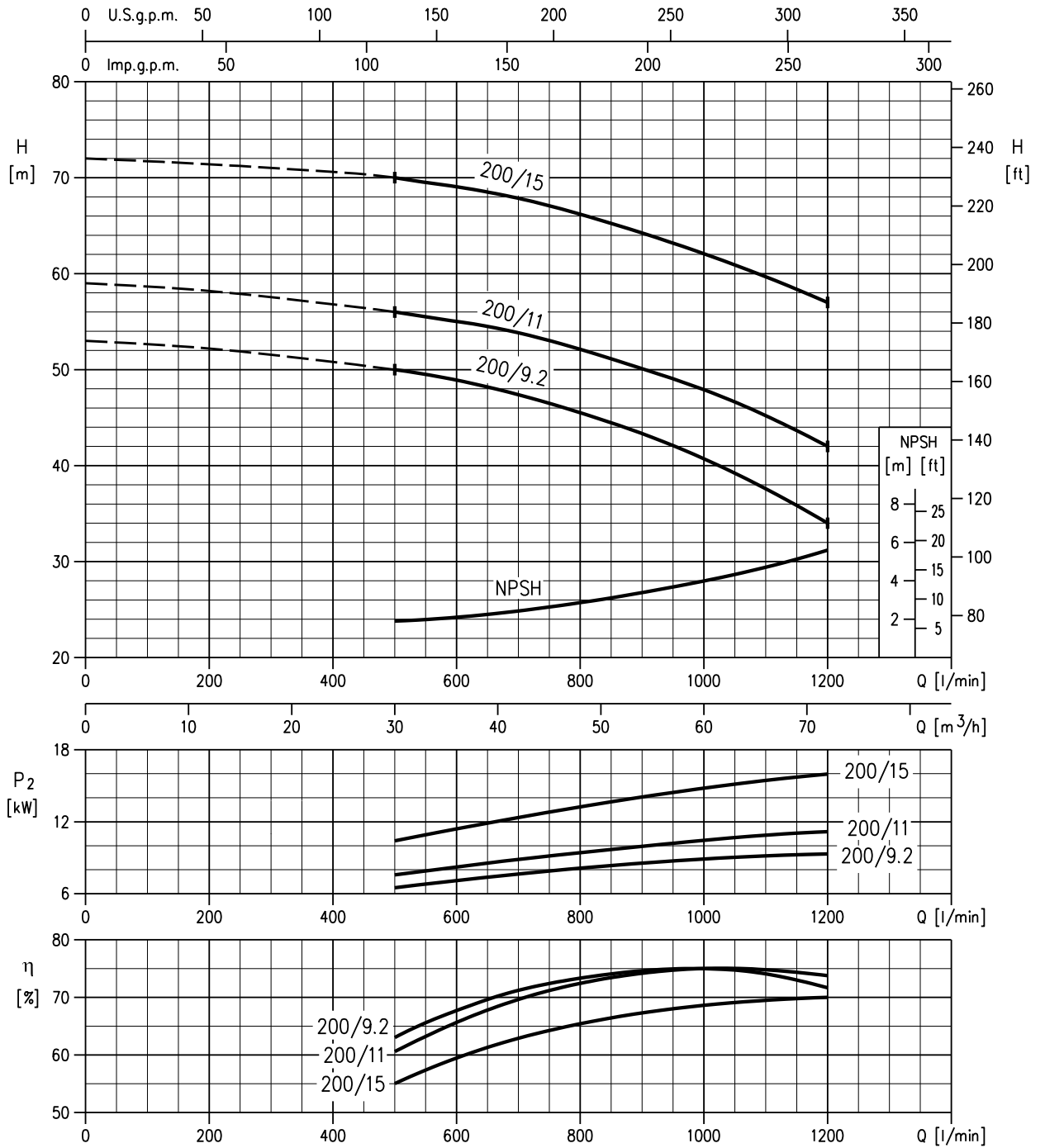

Rotation speed $\approx 2900 \text{ min}^{-1}$
 Test standard: ISO 9906 – Annex A

CONSTRUCTIONS - EXPLODED VIEW

2 Pole 50Hz

Typical construction

V14

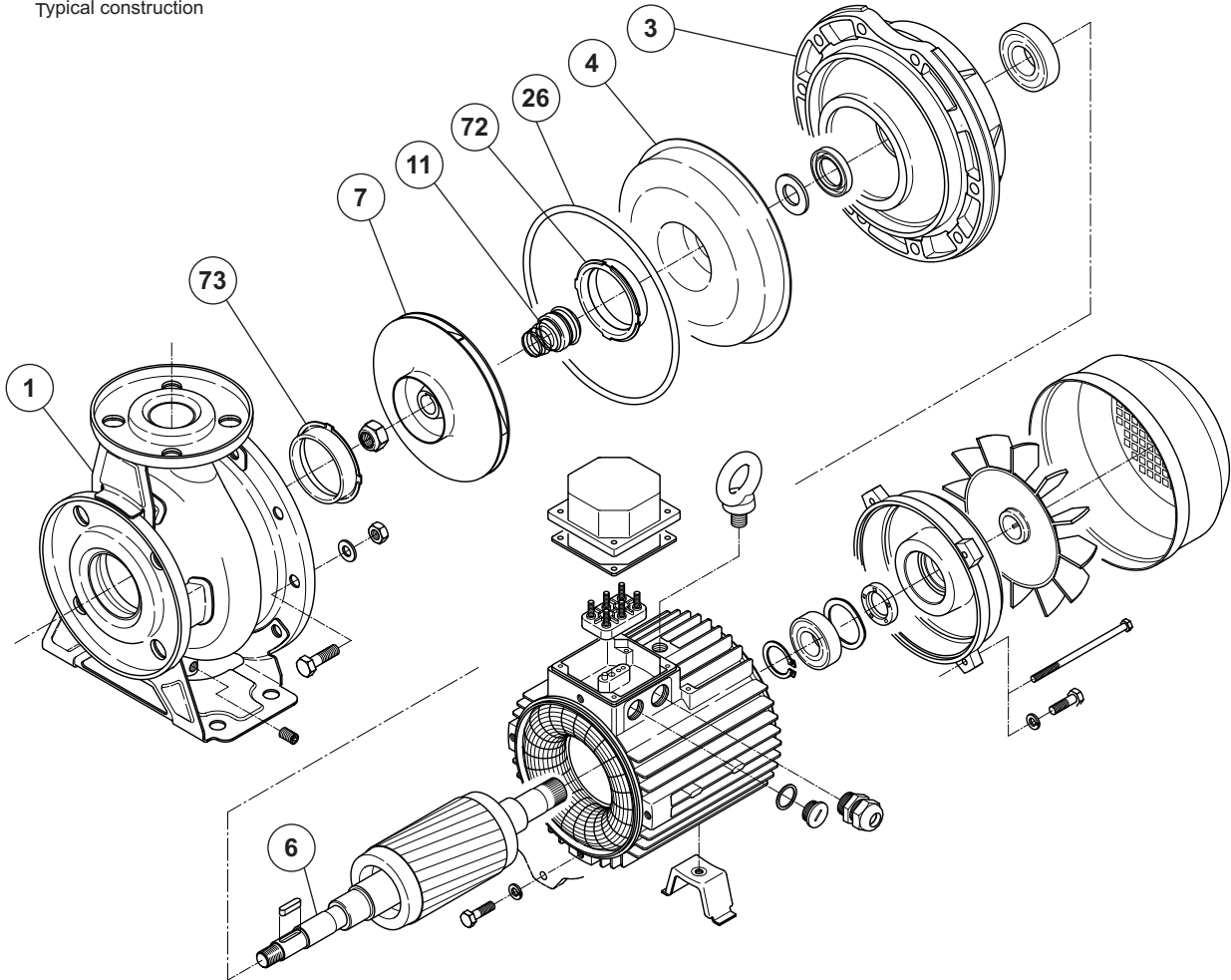

Item	Description	Suits models	Materials
1	Casing	All 32, 40 & 50 models	304 Stainless Steel - stamped
3	Motor bracket	All models	Cast Iron
4	Casing cover	All 32, 40 & 50 models	316L Stainless Steel stamped
6	Shaft (& rotor)	All models <small>(Material refers to part in contact with liquid)</small>	304 Stainless Steel
7	Impeller	All 32, 40 & 50 models	304 Stainless Steel - stamped
11	Mechanical seal	All models	Carbon/Ceramic/NBR <small>Carbon/Ceramic/Viton - High Temp. Option SiC/SiC/Viton - Hard Face Option</small>
26	O-Ring (casing)	All models	NBR <small>Viton - when optional seals fitted</small>
72	Casing ring (rear)	32-200, 40-200, 50-125, 160, 200	304 Stainless Steel - stamped
73	Casing ring (front)	All models	304 Stainless Steel - stamped

Casing



Stamped

Impeller



Stamped

Casing Cover



Stamped

300

MECHANICAL SEAL (standard and H version)

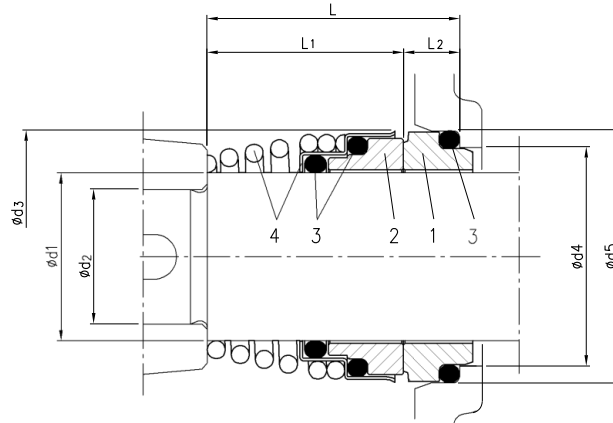

Version	Pump type	Dimensions								Material			
		d1	d2	d3	d4	d5	L	L1	L2	1 Stationary seal ring	2 Rotary seal ring	3 Rubber	4 Frame + Spring
Standard	32-125/160/200	22	19	38	31	37	37.5	27.5	10	Carbon	Ceramic	NBR	316L SS
	40-125/160/200	22	19	38	31	37	37.5	27.5	10	Carbon	Ceramic	NBR	316L SS
	50-125/160/200	22	19	38	31	37	37.5	27.5	10	Carbon	Ceramic	NBR	316L SS
H	32-125/160/200	22	19	38	31	37	37.5	27.5	10	Carbon	Ceramic	FPM	316L SS
	40-125/160/200	22	19	38	31	37	37.5	27.5	10	Carbon	Ceramic	FPM	316L SS
	50-125/160/200	22	19	38	31	37	37.5	27.5	10	Carbon	Ceramic	FPM	316L SS

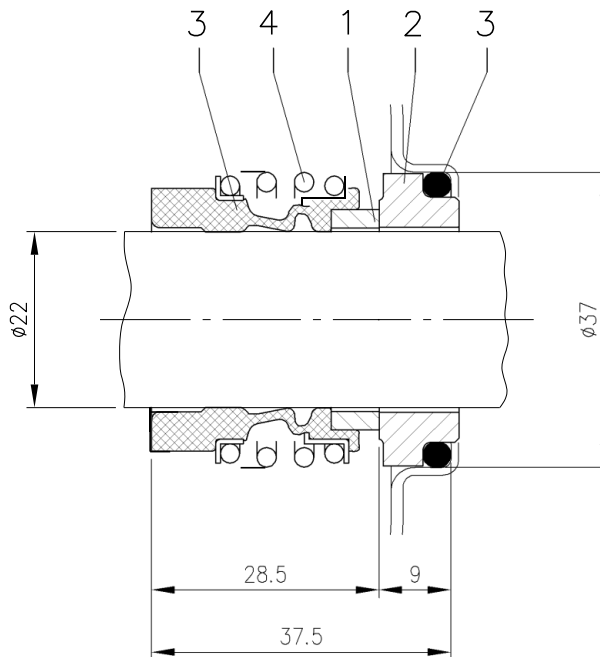

MECHANICAL SEAL (HS version)

Pump type	Material			
	1 Stationary seal ring	2 Rotary seal ring	3 Rubber	4 Frame + spring
32-125/160/200	SiC	SiC	FPM	316Ti SS
40-125/160/200	SiC	SiC	FPM	316Ti SS
50-125/160/200	SiC	SiC	FPM	316Ti SS

THREE PHASE

STAR CONNECTION

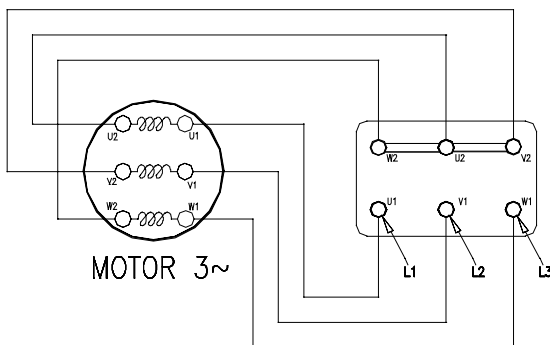

DELTA CONNECTION

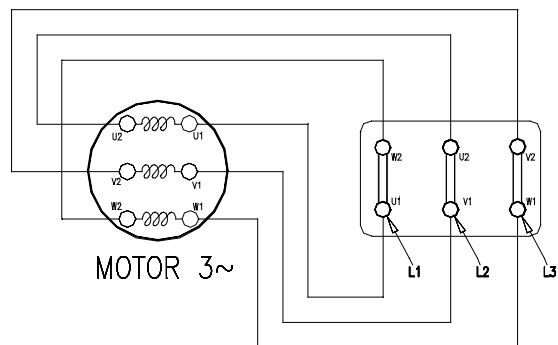

FOR MOTOR 4 kW AND BELOW

DELTA CONNECTION 230 V

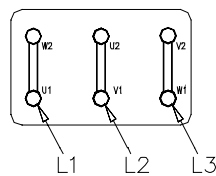

STAR CONNECTION 400 V

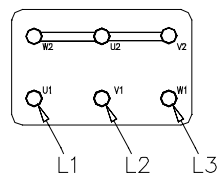

FOR MOTOR 5.5 kW AND ABOVE

DELTA CONNECTION 400 V

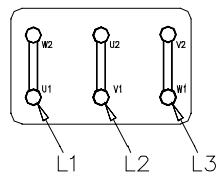

STAR CONNECTION 690 V

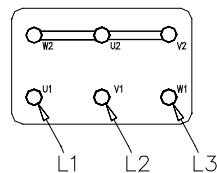

COUNTERFLANGE ZINCKED STEEL

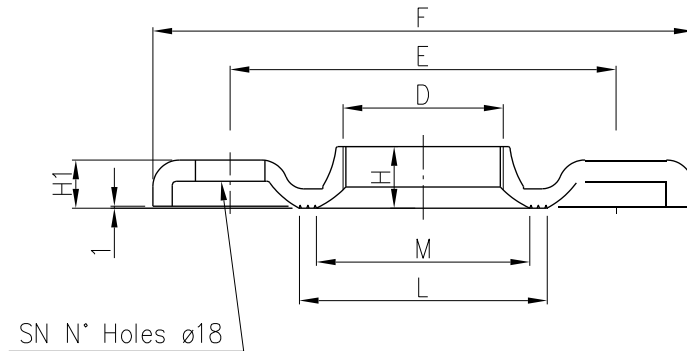

Counter flange									Screw	
DN	D	E	F	H	H1	L	M	SN	DIMENSIONS	MATERIAL
32	G 1 1/4	100	140	15	11.5	67	50	4	M16x55	Gv. Steel 8.8 strength class ISO 898-1
40	G 1 1/2	110	150	17.5	11.5	72	58	4		
50	G2	125	165	19	15	89	70	4		

COUNTERFLANGE EN 1.4301 (AISI 304)

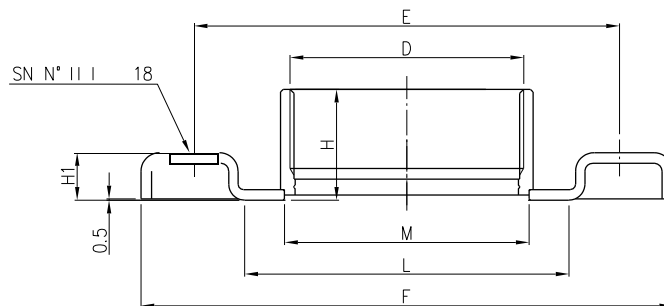

Counter flange									Screw	
DN	D	E	F	H	H1	L	M	SN	DIMENSIONS	MATERIAL
32	G 1 1/4	100	140	29.5	14	66	44	4	M16x55	A2-70 class ISO 3506-1
40	G 1 1/2	110	150	29.5	14	71	50.5			
50	G 2	125	165	34	16	83	63			

GASKET

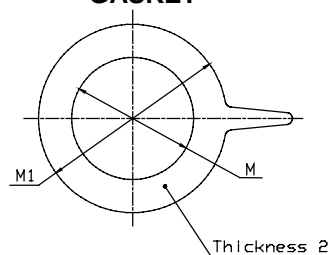

DIN	M	M1
32	38	82
40	50	93
50	60	107
65	80	125

Material : EPDM

DIMENSIONS

2 Pole 50Hz

V14

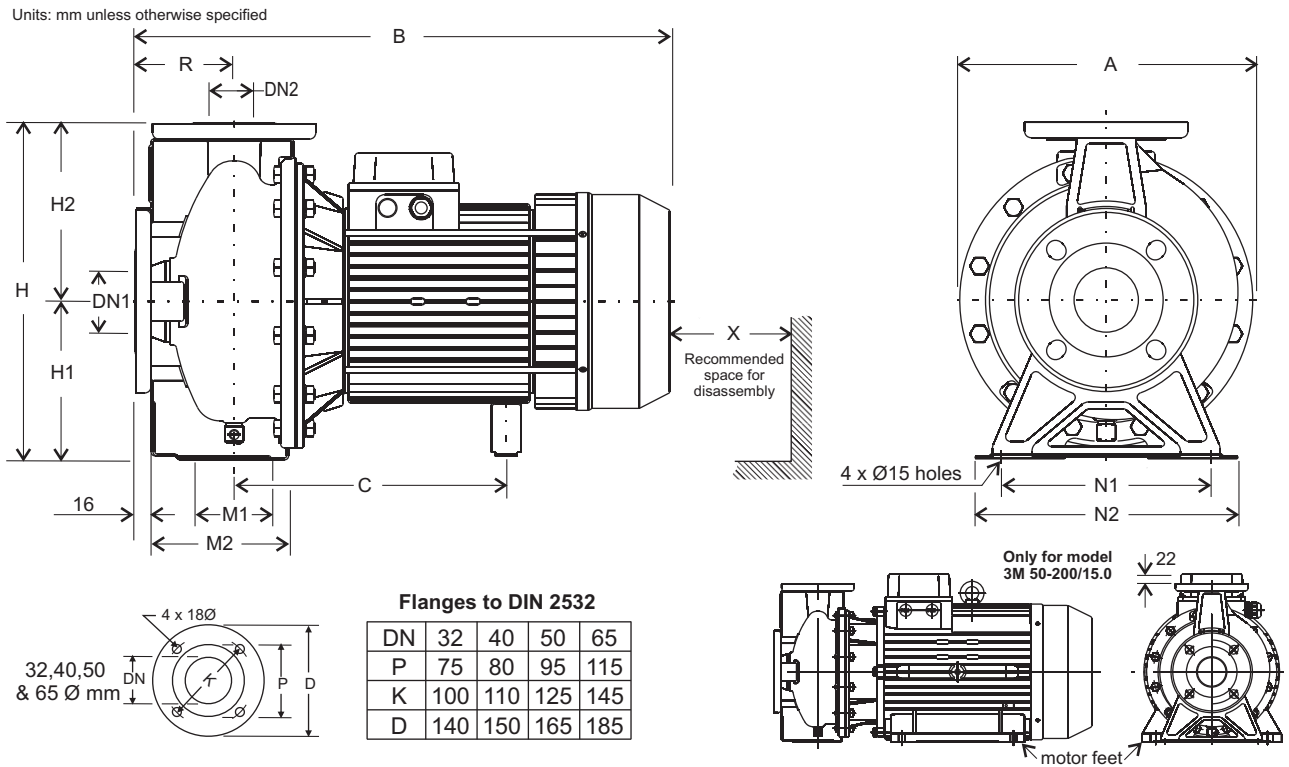

FLC = Full Load Current

DN2 x DN1	2 Pole Pump Model	FLC 3 Phase 400 V	Dimensions												Weight (kg)
			A	B	C	R	H1	H2	H	M1	M2	N1	N2	X	
32 mm x 50 mm	3M 32-125/1.1	3.2 A	213	407	230	80	112	140	252	70	114	140	190	110	24
	3M 32-160/1.5	3.2 A	254	407	230	80	132	160	292	70	118	190	240	110	27
	3M 32-160/2.2	4.5 A	254	432	255	80	132	160	292	70	118	190	240	110	28
	3M 32-200/3.0	6.1 A	296	471	255	80	160	180	340	70	119	190	240	110	35
	3M 32-200/4.0	8.7 A	296	494	253	80	160	180	340	70	119	190	240	110	38
	3M 32-200/5.5	10.4 A	296	519	275	80	160	180	340	70	119	190	240	110	52
40 mm x 65 mm	3M 40-125/1.5	3.2 A	213	407	230	80	112	140	252	70	114	160	210	115	25
	3M 40-125/2.2	4.5 A	213	432	255	80	112	140	252	70	114	160	210	115	26
	3M 40-160/3.0	6.1 A	254	471	255	80	132	160	292	70	118	190	240	115	37
	3M 40-160/4.0	8.7 A	254	494	253	80	132	160	292	70	118	190	240	115	41
	3M 40-200/5.5	10.4 A	296	539	275	100	160	180	340	70	115	212	265	115	53
	3M 40-200/7.5	13.7 A	296	539	275	100	160	180	340	70	115	212	265	115	56
	3M 40-200/11.0	21.9 A	296	595	359	100	160	180	340	70	115	212	265	115	67
50 mm x 65 mm	3M 50-125/2.2	4.5 A	254	452	255	100	132	160	292	70	114	190	240	125	32
	3M 50-125/3.0	6.1 A	254	491	255	100	132	160	292	70	114	190	240	125	35
	3M 50-125/4.0	8.7 A	254	514	253	100	132	160	292	70	114	190	240	125	41
	3M 50-160/5.5	10.4 A	296	539	275	100	160	180	340	70	115	212	265	125	47
	3M 50-160/7.5	13.7 A	296	539	275	100	160	180	340	70	115	212	265	125	56
	3M 50-200/9.2	16.8 A	296	595	359	100	160	200	360	70	115	212	265	125	64
	3M 50-200/11.0	21.9 A	296	595	359	100	160	200	360	70	115	212	265	125	67
	3M 50-200/15.0	28.3 A	314	723	499.5	100	160	200	360	70	115	212	265	125	102

PACKING AND WEIGHT

2 Pole 50Hz

V14

Pump type	Packing [mm]			Weight [kgf]	Pack type
	X	Y	Z		
32-125/1.1	250	300	450	29	1
432-160/1.5	280	330	430	31.7	
32-160/2.2		340	490	33.5	
32-200/3	350	488	550	41	2
32-200/4				44	
32-200/5.5				60.5	
40-125/1.5	250	300	450	30	1
40-125/2.2	280	340	490	31.5	2
40-160/3	350	488	550	28.8	
40-160/4				46.5	
40-200/5.5				61.5	
40-200/7.5				65	
40-200/11				77	
50-125/2.2				280	340
50-125/3	350	488	550	37	2
50-125/4				47	
50-160/5.5				51.5	
50-160/7.5				64.5	
50-200/9.2				73.5	
50-200/11				76.5	
50-200/15	390	532	880	110	

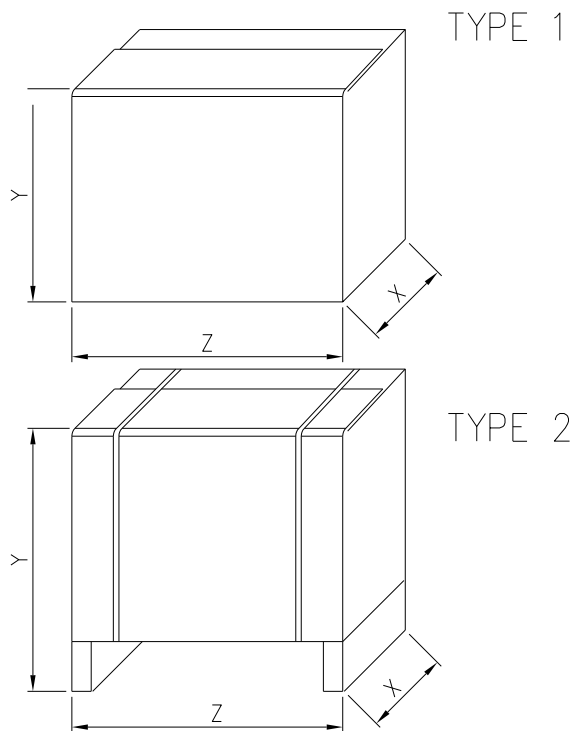

TECHNICAL DATA - MOTOR DATA

2 Pole 50Hz

V14

Model	Power		Efficiency				Input [kW]	Full load current [A]			Locked rotor current [A]		
	[kW]	[HP]		η %				230 V	400 V	690 V	230 V	400 V	690 V
				50%	75%	100%							
3M 32-125/1.1	1.1	1.5	IE2	79.5	82.0	82.5	1.82	5.6	3.2	-	57.0	33.0	-
3M 32-160/1.5	1.5	2.0	IE2	79.5	82.0	82.5	1.82	5.6	3.2	-	57.0	33.0	-
3M 32-160/2.2	2.2	3.0	IE2	83.1	85.7	86.2	2.55	7.8	4.5	-	75.0	43.5	-
3M 32-200/3.0	3.0	4.0	IE2	85.0	86.7	86.3	3.48	10.6	6.1	-	100.0	57.7	-
3M 32-200/4.0	4.0	5.5	IE2	84.3	87.2	87.8	4.56	15.1	8.7	-	151.0	87.0	-
3M 32-200/5.5	5.5	7.5	IE2	82.9	86.0	87.4	6.29	-	10.4	6.0	-	116.0	67.0
3M 40-125/1.5	1.5	2.0	IE2	79.5	82.0	82.5	1.82	5.6	3.2	-	57.0	33.0	-
3M 40-125/2.2	2.2	3.0	IE2	83.1	85.7	86.2	2.55	7.8	4.5	-	75.0	43.5	-
3M 40-160/3.0	3.0	4.0	IE2	85.0	86.7	86.3	3.48	10.6	6.1	-	100.0	57.7	-
3M 40-160/4.0	4.0	5.5	IE2	84.3	87.2	87.8	4.56	15.1	8.7	-	151.0	87.0	-
3M 40-200/5.5	5.5	7.5	IE2	82.9	86.0	87.4	6.29	-	10.4	6.0	-	116.0	67.0
3M 40-200/7.5	7.5	10.0	IE2	86.1	88.2	88.8	8.45	-	13.7	7.9	-	140.0	81.0
3M 40-200/11	11.0	15.0	IE2	88.9	90.3	90.2	12.20	-	21.9	12.7	-	186.0	108.0
3M 50-125/2.2	2.2	3.0	IE2	83.1	85.7	86.2	2.55	7.8	4.5	-	75.0	43.5	-
3M 50-125/3.0	3.0	4.0	IE2	85.0	86.7	86.3	3.48	10.6	6.1	-	100.0	57.7	-
3M 50-125/4.0	4.0	5.5	IE2	84.3	87.2	87.8	4.56	15.1	8.7	-	151.0	87.0	-
3M 50-160/5.5	5.5	7.5	IE2	82.9	86.0	87.4	6.29	-	10.4	6.0	-	116.0	67.0
3M 50-160/7.5	7.5	10.0	IE2	86.1	88.2	88.8	8.45	-	13.7	7.9	-	140.0	81.0
3M 50-200/9.2	9.2	12.5	IE2	88.6	90.0	89.9	10.23	-	16.8	9.7	-	166.0	96.0
3M 50-200/11	11.0	15.0	IE2	88.9	90.3	90.2	12.20	-	21.9	12.7	-	186.0	108.0
3M 50-200/15	15.0	20.0	IE2	89.3	91.0	91.1	18.00	-	30.0	17.3	-	246.0	143.0

Ball bearing		
	Pump side	Fan side
3M 32-125/1.1	6205-SRSH	6205-SRSH
3M 32-160/1.5		
3M 32-160/2.2		
3M 32-200/3		
3M 32-200/4	6206-2RS1	6206-2RS1
3M 32-200/5.5	6306-2RS1	
3M 40-125/1.5	6205-SRSH	6205-SRSH
3M 40-125/2.2		
3M 40-160/3		
3M 40-160/4	6206-2RS1	6206-2RS1
3M 40-200/5.5	6306 2RS1	
3M 40-200/7.5	6308-2RS1	6208-2RS1
3M 40-200/11		
3M 50-125/2.2		
3M 50-125/3		
3M 50-125/4	6206-2RS1	6206-2RS1
3M 50-160/5.5	6306-2RS1	
3M 50-160/7.5		
3M 50-200/9.2	6308-2RS1	6208-2RS1
3M 50-200/11		
3M 50-200/15		

Model	Power		L _{PA} - dB(A) *
	[kW]	[HP]	
3M 32-125/1.1	1.1	1.5	<70
3M 32-160/1.5	1.5	2.0	
3M 32-160/2.2	2.2	3.0	
3M 32-200/3.0	3.0	4.0	71
3M 32-200/4.0	4.0	5.5	
3M 32-200/5.5	5.5	7.5	75
3M 40-125/1.5	1.5	2.0	<70
3M 40-125/2.2	2.2	3.0	
3M 40-160/3.0	3.0	4.0	71
3M 40-160/4.0	4.0	5.5	
3M 40-200/5.5	5.5	7.5	75
3M 40-200/7.5	7.5	10.0	
3M 40-200/11	11.0	15.0	80
3M 50-125/2.2	2.2	3.0	<70
3M 50-125/3.0	3.0	4.0	71
3M 50-125/4.0	4.0	5.5	
3M 50-160/5.5	5.5	7.5	75
3M 50-160/7.5	7.5	10.0	
3M 50-200/9.2	9.2	12.5	80
3M 50-200/11	11.0	15.0	
3M 50-200/15	15.0	20.0	

* Mean value of several measures at 1m distance around the pump
Tolerance ± 2.5 dB.

500